

Dismantling Joints

These fitting instructions apply to Viking Johnson Dismantling Joints **up to DN300**

Fig 1.

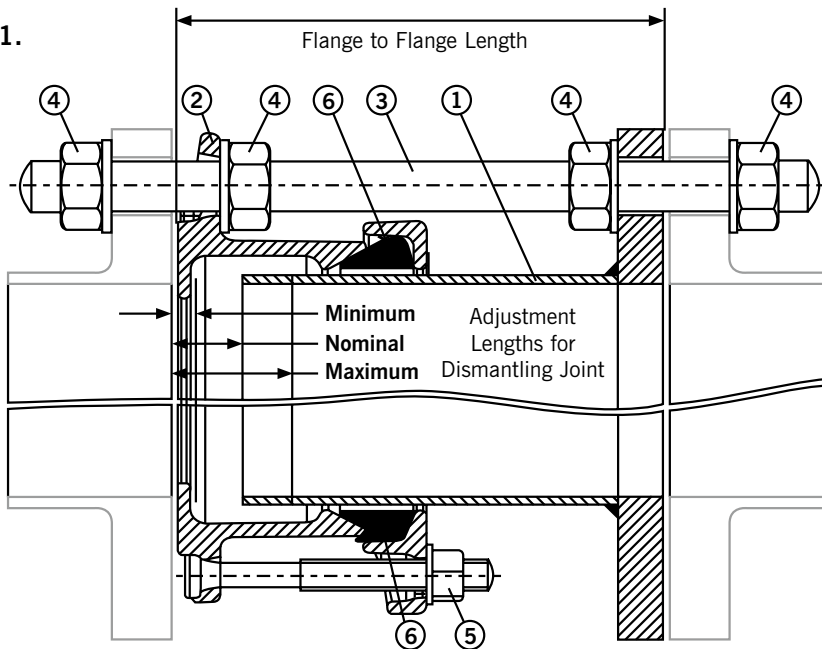

1. Flange Spigot
2. Flange Adaptor
3. Tie Rods
4. Tie Rod Nut and Washer
5. Flange Adaptor Nut and Washer
6. Gasket

Maximum Adjustment Length for sizes up to DN300 = 40mm
Stud Torque for M12 Bolts = 55 – 65 Nm

Viking Johnson Dismantling Joints include a flange adaptor, a flanged spigot pipe and tie rods.

Each Dismantling Joint has a specified flange-to-flange dimension, which positions the Dismantling Joint at its mid point. The plus and minus dimension specified on the label are the maximum and minimum amounts of movement available to take up any site tolerances, i.e. they provide the maximum and minimum flange-to-flange dimensions respectively.

Check grade of gasket supplied with the product is suitable for conveyed medium.

Dismantling Joints up to DN300

1. Position the spigot inside the flange adaptor until the front edge of the spigot is flush with the face of the flange adaptor (minimum flange to flange distance).
2. Position the Dismantling Joint between the two flanges to which it is to be connected. Withdraw the spigot until all the free play is taken up, **ensuring the maximum flange-to-flange dimension is not exceeded.**
3. Position flange connecting gaskets (not supplied, but recommend the use of IBC gaskets) between both flange sets, and loosely assemble flange connecting bolts.
4. Remove all nuts and washers from the tie rods (supplied) and insert them from one side in their appropriate positions. The nuts and washers have to be threaded back onto the tie rod in sequence as they are installed.
5. Tighten the flange connecting bolts (not supplied) and tie rods in accordance with standard procedures.
6. Tighten diametrically opposed flange adaptor studs giving the nuts one or two turns at a time to draw up the end ring evenly. The studs must be thoroughly tightened to the figures given above with the drawing, **working around the flange adaptor as many times as necessary.** Rubber may be seen to extrude into the gap between the end ring and spigot pipe.

REV02

Dismantling Joints

These fitting instructions apply to Viking Johnson Dismantling Joints **over DN300**

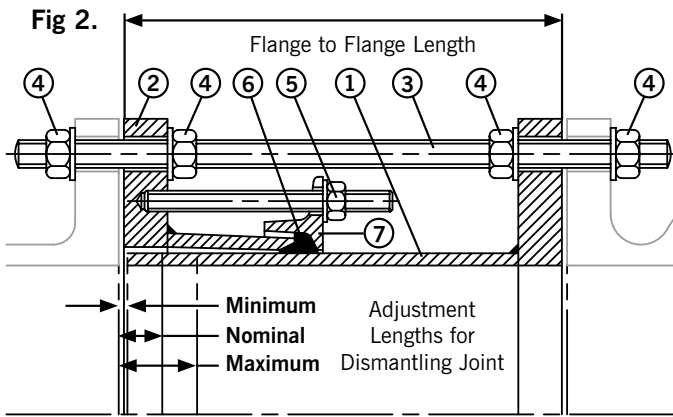

1. Flange Spigot
2. Flange Adaptor Body
3. Tie Rods
4. Tie Rod Nut and Washer
5. Flange Adaptor Nut and Washer
6. Gasket
7. Endring

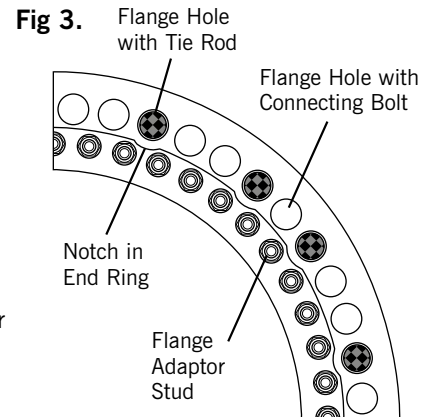

Maximum Adjustment Length for sizes over DN300
(see product label for details)

Stud Torque for M12 Bolts = 55 – 65 Nm,
M16 Bolts = 95 – 120 Nm

Sleeve Length	Maximum Adjustment
73mm	50mm
87mm	60mm
125mm	125mm

Viking Johnson Dismantling Joints include a flange adaptor, a flanged spigot pipe and tie rods.

Each Dismantling Joint has a specified flange-to-flange dimension, which positions the Dismantling Joint at its mid point. The plus and minus dimension specified on the label are the maximum and minimum amounts of movement available to take up any site tolerances, i.e. they provide the maximum and minimum flange-to-flange dimensions respectively.

Check grade of gasket supplied with the product is suitable for conveyed medium.

Dismantling Joints over DN300

- A. Place the end ring over the spigot pipe end, ensuring that the gasket chamber faces the plain end and the vertical end faces the flange.
Lubricate the gasket thoroughly with a thin film of any non-oil based water quality approved pipe joint lubricant and stretch it onto the spigot pipe end, ensuring that the thicker or vertical end is towards the end ring.
- B. Position the spigot inside the flange adaptor until the front edge of the spigot is flush with the face of the flange adaptor (minimum flange to flange distance).
- C. Position the Dismantling Joint between the two flanges to which it is to be connected. Withdraw the spigot until all the free play is taken up, **ensuring the maximum flange-to-flange dimension is not exceeded.**
- D. Position flange connecting gaskets (not supplied, but recommend the use of IBC gaskets) between both flange sets, and loosely assemble flange connecting bolts.
- E. Remove all nuts and washers from the tie rods (supplied) and insert them from one side in their appropriate positions - **the end ring has been marked with notches to identify the correct positions for the tie rods to ensure maximum load capability (see Fig 3).** The nuts and washers have to be threaded back onto the tie rod in sequence as they are installed. For tie rods sized larger than M48 (2"), double nuts must be used (supplied) at each end.
- F. Tighten the flange connecting bolts (not supplied) and tie rods in accordance with standard procedures. Torque the tie rods to the same level as flange connecting bolts.
- G. Slide the gasket forward into the gasket chamber of the flange adaptor (the end ring may assist in this operation).
- H. Bring the end ring into position, locate the studs and fit the washers and nuts finger tight.
- I. Tighten diametrically opposed flange adaptor studs giving the nuts one or two turns at a time to draw up the end ring evenly. The studs must be thoroughly tightened to the figures given above with the drawing, **working around the flange adaptor as many times as necessary.** Rubber may be seen to extrude into the gap between the end ring and spigot pipe.

REV02