

# Smartstream Poo Pit Maintenance Shaft

A rotomolded lightweight one-piece unit, which eliminates root intrusion and groundwater ingress.



TECHNICAL GUIDE: **TC2.1**

## Applications

Sewer and stormwater

Inspection chambers

## Product Attributes

Welded one piece unit

PE does not suffer from gas attack (either internal or external).

Does not require concrete encasement

## Approvals/Standards

AS/NZS 4798:2005, Polyethylene

## Maintenance Shafts

WSA 137-2013 Maintenance Shafts and Maintenance Chambers for Sewerage in the 150mm and 225mm sizes with PVC RRJ, PVC SWJ and PE Spigot connections

## Quality

ISO 9001:2008 Quality Management Standard

As part of the Smartstream family of products, the Poo Pit is a lightweight, easy to handle maintenance shaft alternative.

### Product Overview

- Lightweight and durable. No heavy lifting equipment required.
- With Poo Pit almost any inlet combination is possible. The spherical base allows multiple inlets to be attached at any angle between 45° and 315° from the downstream and at specified grades.
- Manufactured to suit all types and sizes of pipe up to 250 mm. Other sizes on request.

### Design Specifications

- Typical installation from 600 mm to 3 m invert (subject to local Council specification).
- Rotomolded polyethylene construction.
- Robust 13 mm wall thickness.
- 600 mm spherical base has excellent hydraulic properties.
- All units are pressure tested prior to despatch.
- Range of fittings available to accommodate most sewer line types including: PVC, PE, Clay and AC.
- In order to manufacture the product to customer requirements, a drill order sheet must be completed and sent to Hygrade fabrication.

### Installation

- Bedding material must be in accordance with local council requirements.
- Connect downstream and ensure that the top of the chamber is level.
- Pack/Tamp to support product.
- Connect upstream(s).
- Backfill and compact.
- Install concrete cover slab and access cover/top hat.
- Refer to diagrams for details.

**TABLE 1** Solid Top Round Frames and Covers (Top Hat)

Product Code	Description
BSTOPC375B	Cover 375 mm Class B
BSTOPF375B	Frame 375 mm Class B
BSTOPC375D	Cover 375 mm Class D
BSTOPF375D	Frame 375 mm Class D

As each Smartstream Smart Pit is made to suit your individual requirements, please contact Hygrade Water with your project details for pricing.



**FIG. 1** Smartstream Poo Pit installation on a 160 OD PE line



**FIG. 2** Smartstream Poo Pit is 100% watertight

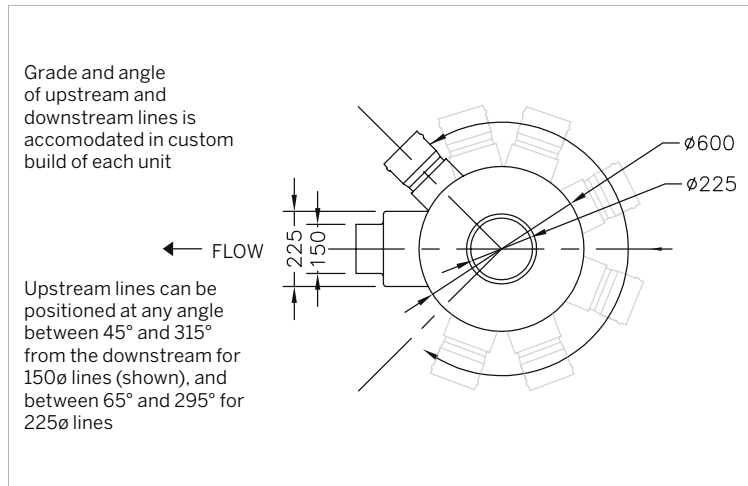

**FIG. 4** Plan View (Shows range of upstream angle)

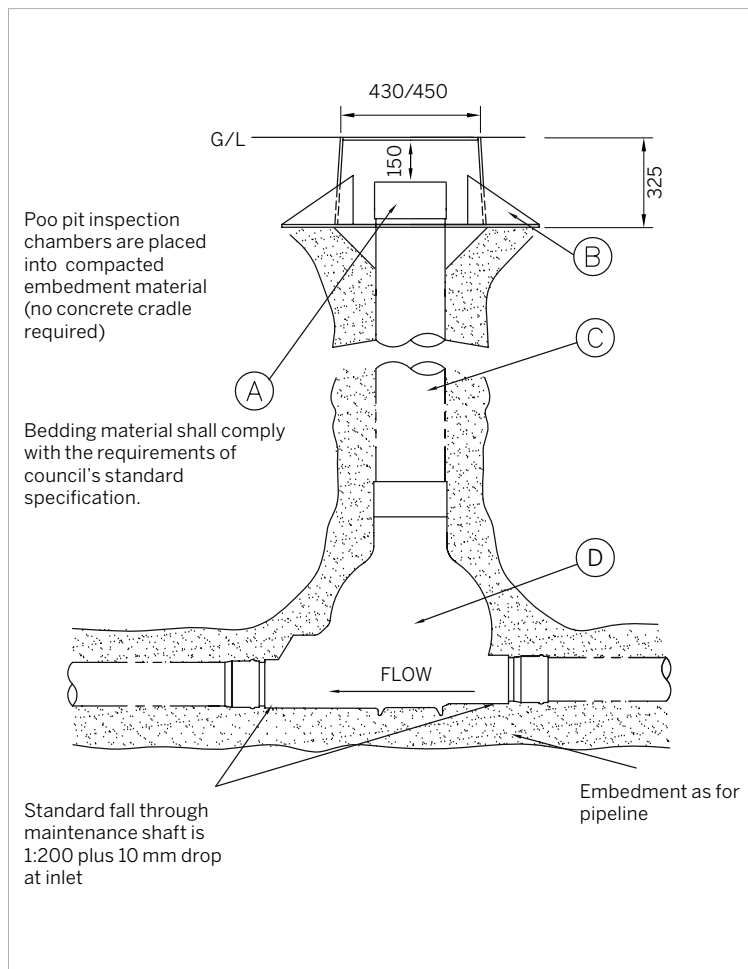

**FIG. 3** Side Elevation

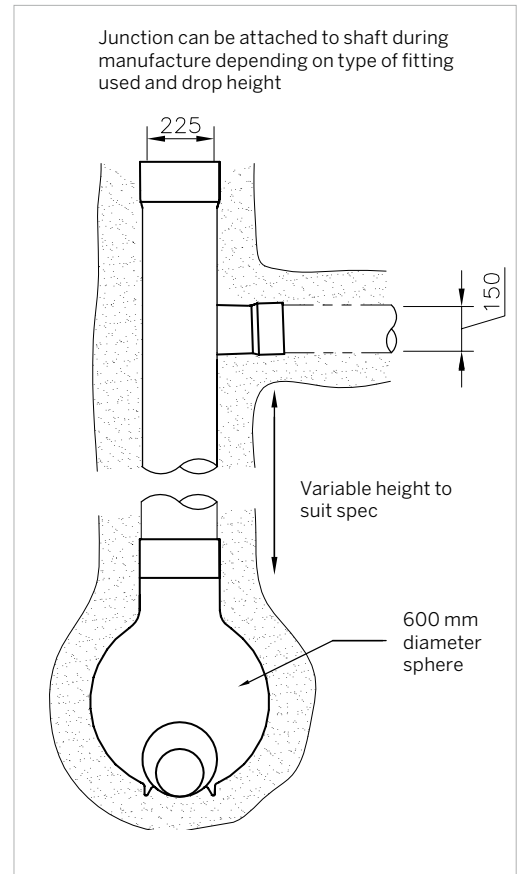
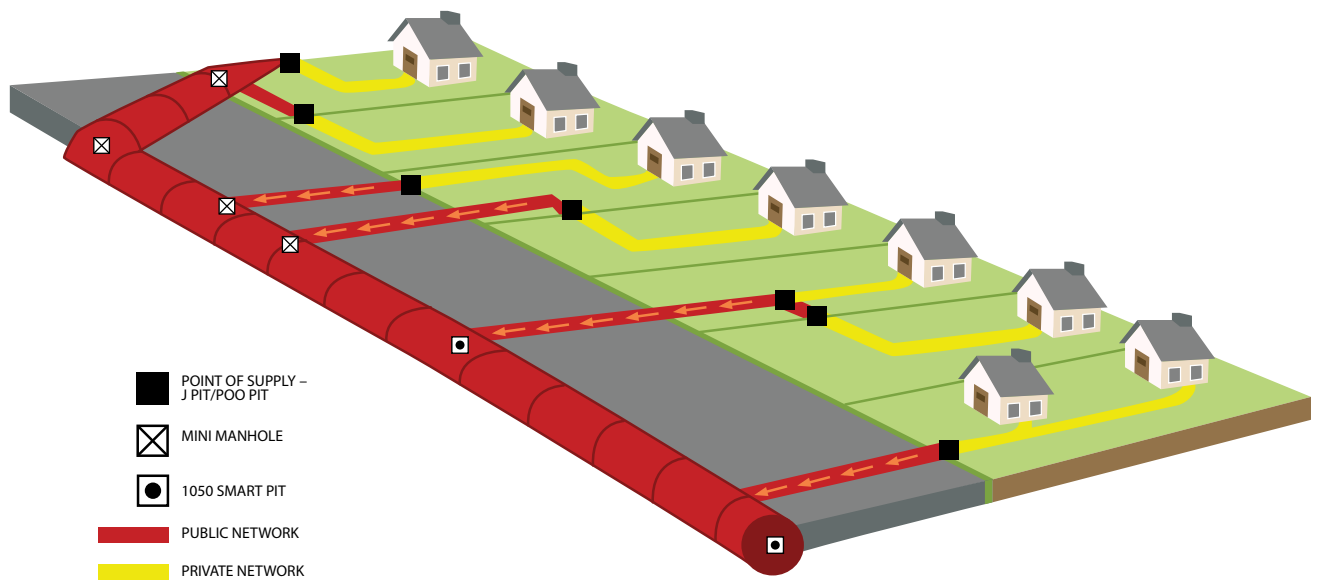

**FIG. 5** Front Elevation

**TABLE 2** Smartstream Poo Pit Components

Item	Description	Material
A	Vertical riser cap	PVC
B	C.I. trafficable cover/top hat	CAST IRON
C	DN 225 PVC riser shaft	PVC
D	Smartstream Poo Pit	MDPE (Polythylene)

## Typical Smartstream Application



## Smartstream Family of Products

The Mini Manhole is part of the Smartstream family of products, the most complete portfolio of PE solutions for drainage and sewer applications.



Scan for more information

**Disclaimer:** While every effort has been made to ensure that the information in this document is correct and accurate, users of Hygrade Water product or information within this document must make their own assessment of suitability for their particular application. Product dimensions are nominal only, and should be verified if critical to a particular installation. No warranty is either expressed, implied, or statutory made by Hygrade Water unless expressly stated in any sale and purchase agreement entered into between Hygrade Water and the user.

January 2020

0800 494 723  
hygradewater.co.nz

102 Neilson Street  
Onehunga, Auckland 1061, New Zealand  
PO Box 58 142, Botany, Auckland 2163

**HW** HYGRADE  
WATER