

Gillies Swing Check Valves

The Gillies Swing Check valve is a robust, double flanged, soft seated check valve for preventing reverse flow of liquids in pipelines.



TECHNICAL GUIDE: **VH4.5**

Applications

Pump stations

Tank filling

Booster pumps

Product Attributes

16 bar rated

Gunmetal seat ring

Moulded polyurethane seal on flap

Stainless steel shaft

Approvals/Standards

Compliant with AS/NZ 4158:2003

Compliant with AS 4020:2005

Quality

ISO 9001:2008 Quality
Management Systems

For use in back flow management on pump applications. Available with outside lever and counterweight options for higher head pressures and pipe line back flush.

Application

For the purpose of allowing flow to pass in one direction and to automatically close in the event of flow stoppage or reversal. Used in pressure and gravity pipe lines.

Features

- Cast iron body
- Gunmetal flap for sizes up to and including DN200mm
- Cast iron, polymeric coated flap for sizes 250-300
- Moulded polyurethane resilient seal on flap
- Gunmetal seat on body
- Stainless steel live pivot shaft c/w double O ring seals, keyed to flap
- Polymeric coated

Accessories

Adjustable lever weighted damper available as an extra.

Availability

- Available in sizes from 80mm to 300mm
- Table E flange available in DN 100 & 150

Testing and ratings

- Flanged to AS 4087 Fig. B5
- Maximum working pressure: 16 Bar
- Body test pressure: 24 Bar
- Seat test pressure: 16 Bar
- Maximum service temperature: 40°C

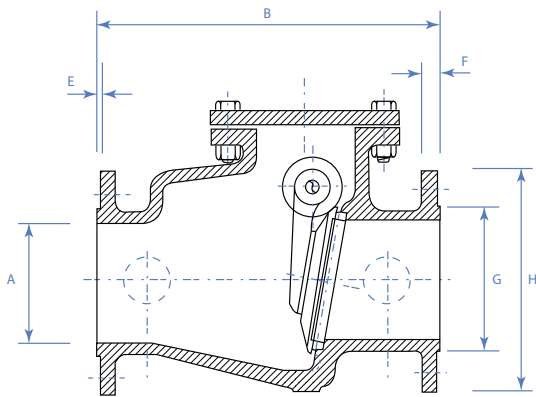

FIG. 1

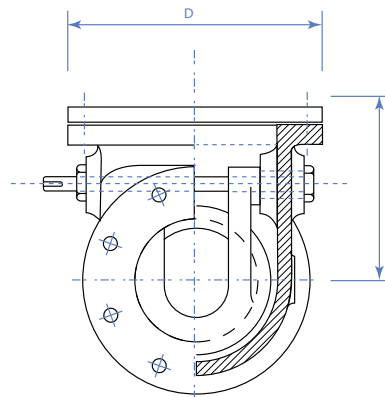

FIG. 2

Lever Operated Item Codes	Free Acting Item Codes	A	B	C	D	E	F	G	H
VCGR080LO	VCGR080FA	80	310	227	162	3	22	132	200
VCGR100LO	VCGR100FA	100	375	255	280	3	24	156	220
VCGR150LO	VCGR150FA	150	445	324	221	3	26	211	285
VCGR200LO	VCGR200FA	200	495	400	261	3	30	266	340
VCGR250LO	VCGR250FA-C	250	622	520	329	3	32	319	405
VCGR300LO	VCGR300FA	300	699	525	379	4	32	370	460



Scan for more information

Disclaimer: While every effort has been made to ensure that the information in this document is correct and accurate, users of Hygrade Water product or information within this document must make their own assessment of suitability for their particular application. Product dimensions are nominal only, and should be verified if critical to a particular installation. No warranty is either expressed, implied, or statutory made by Hygrade Water unless expressly stated in any sale and purchase agreement entered into between Hygrade Water and the user.

March 2022