

Brio 600mm Hinged Stormwater Grate & Frame

Internationally recognised stormwater grate system for where high flow control in intense traffic is required. This locking grate also gives safe and easy access to your network.



TECHNICAL GUIDE: **CG3.1**

Applications

Stormwater grate rated to AS3996:2019 Class E400 for use in carriageways, traffic lanes and wherever intense traffic is the norm

Product Attributes

600mm opening delivers increased flow capture

Retractable integrated locking, lifting handle

Meets HN-H0-72 Transit loadings

Approvals/Standards

Tested to Australian Standard AS3996:2019 Class E400

Quality

Manufactured from ductile iron grade 500-7, in accordance with ISO 1083

Internationally recognised hinged grate system, manufactured in France by EJ.

Features

- Ductile iron — up to 40% lighter than cast iron equivalent, outstanding weight / strength ratio
- Polyethylene cushioning insert anti rattle support seating ring eliminates the risk of vibration and noise
- Equipped with 5 self-centering guides to position the cover within the frame, for better stability and prevention of seating wear
- Patented retractable and integrated lifting and locking handle
- Hinged to allow cover to remain opened at 120° without rotational movement, and includes a mechanism to safely lock at 90° ensuring safety of personnel within. Grate removable at 90°
- Locking key required
- Does not require special lifting tools

Installation

- Octagonal frame maximises rigidity of frame bearing. Locating holes in frame allow for anchoring to chamber.

Testing

- Tested in accordance with EN-124 Class D400 for Europe, and AS3996:2019 to Class E400 for Australasia.

Product Codes

- DIMHBGFH BRIO Grated Cover and Frame
- DIMHLK Locking Key

Flow Rate Estimate BRIO SGR DECOR

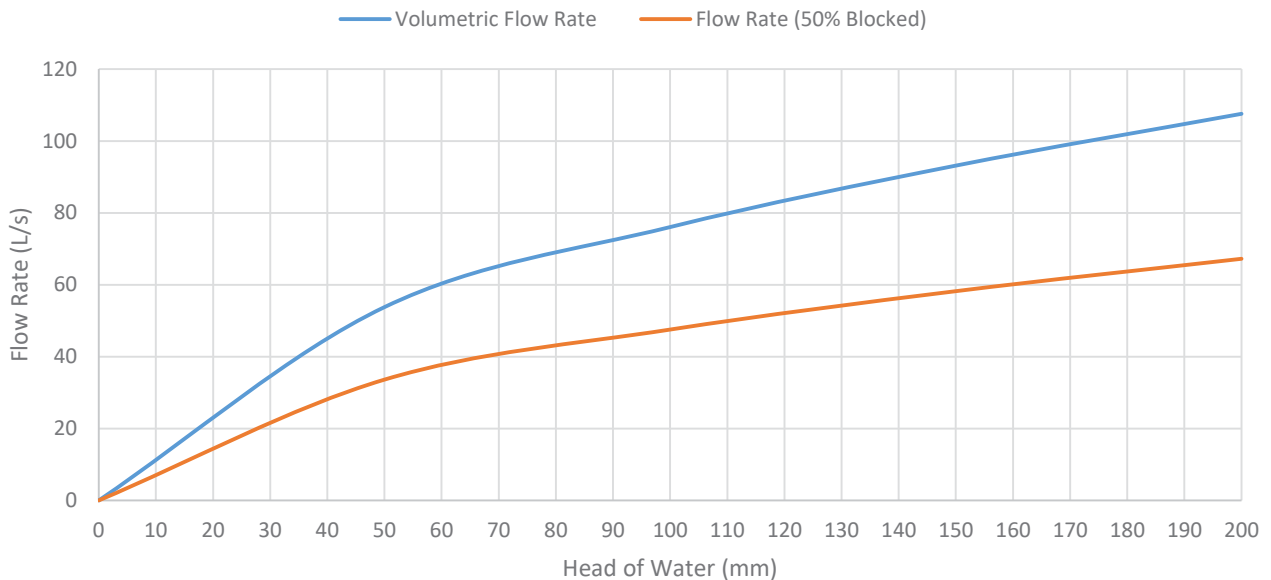

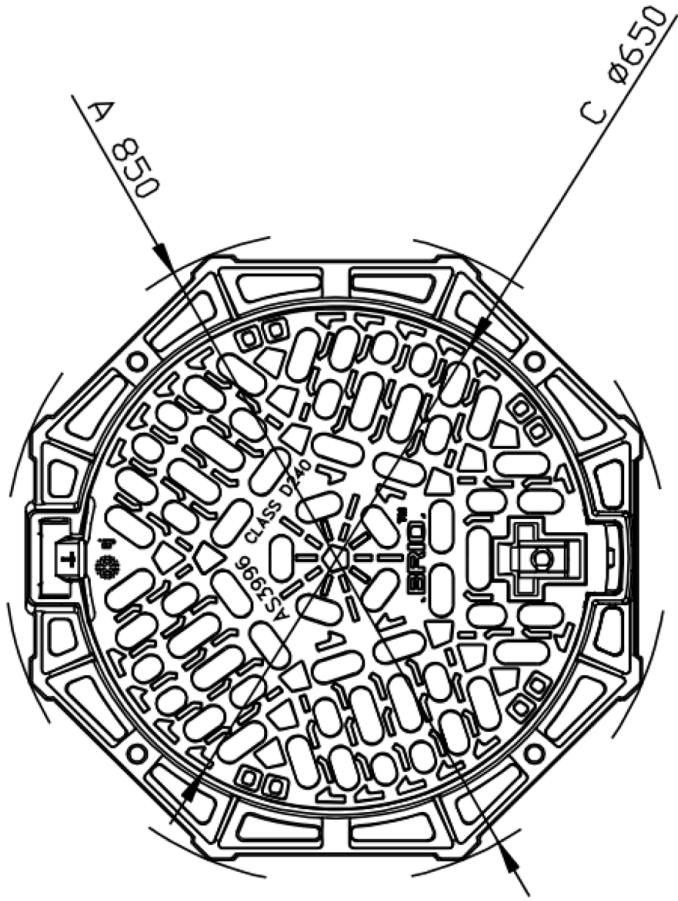
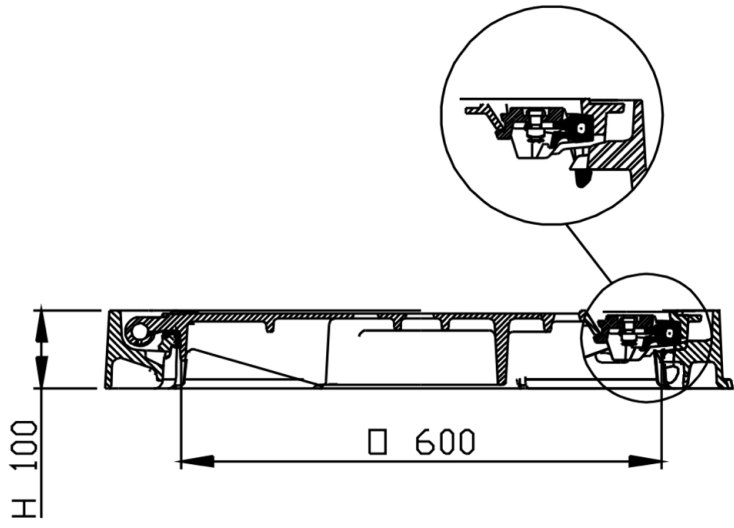



Scan for more
information

Disclaimer: While every effort has been made to ensure that the information in this document is correct and accurate, users of Hygrade Water product or information within this document must make their own assessment of suitability for their particular application. Product dimensions are nominal only, and should be verified if critical to a particular installation. No warranty is either expressed, implied, or statutory made by Hygrade Water unless expressly stated in any sale and purchase agreement entered into between Hygrade Water and the user.

February 2024