

Force Balanced Flex-Tend® Flexible Expansion Joint

Force Balanced Flex-Tend® expansion joints provide seismic resilience and protection from differential settling while absorbing pressure and volume changes.



TECHNICAL GUIDE: **PF8.2**

Applications

Tank settling and other differential settling

Bridge crossings and underground to aerial transitions

Active fault crossings and liquefaction

For Ductile Iron, Steel, PVC, or HDPE pipe

Product Attributes

Ball ends

Telescopic center sections

Low contribution to mechanical thrust

Large movement ranges

Above or below ground installation

Expansion unit will NOT impart a thrust force while under internal pressure. Thrust restraint not required.

Approvals/Standards

All wetted parts coated with NSF61 Approved FBE

100% test program for all completed units

Flanges available in ANSI, AS and EN standards

Quality

NSF-61 Health and Safety Effects

The Force Balanced FLEX-TEND® Flexible Expansion Joint is designed to accommodate pressure induced thrust forces. Utilising an additional water chamber piston that acts in the equal and opposite direction thrust forces and volume changes are absorbed.

Design Specifications

- Constructed of ASTM AS36 Ductile Iron
- Ball ends allow up to 20 degrees of deflection
- Large movement ranges
- Above or below ground installation
- Expansion unit will NOT impart thrust force due to pressure
- No periodic maintenance required

Applications

- Tank settling and other differential settling such as vessel to vessel
- Bridge crossings and other underground to areal transitions
- Active fault crossings and liquefaction
- Near roadways and dams
- Across any unstable ground



FIG. 1 DN200 Force Balanced Flex-Tend

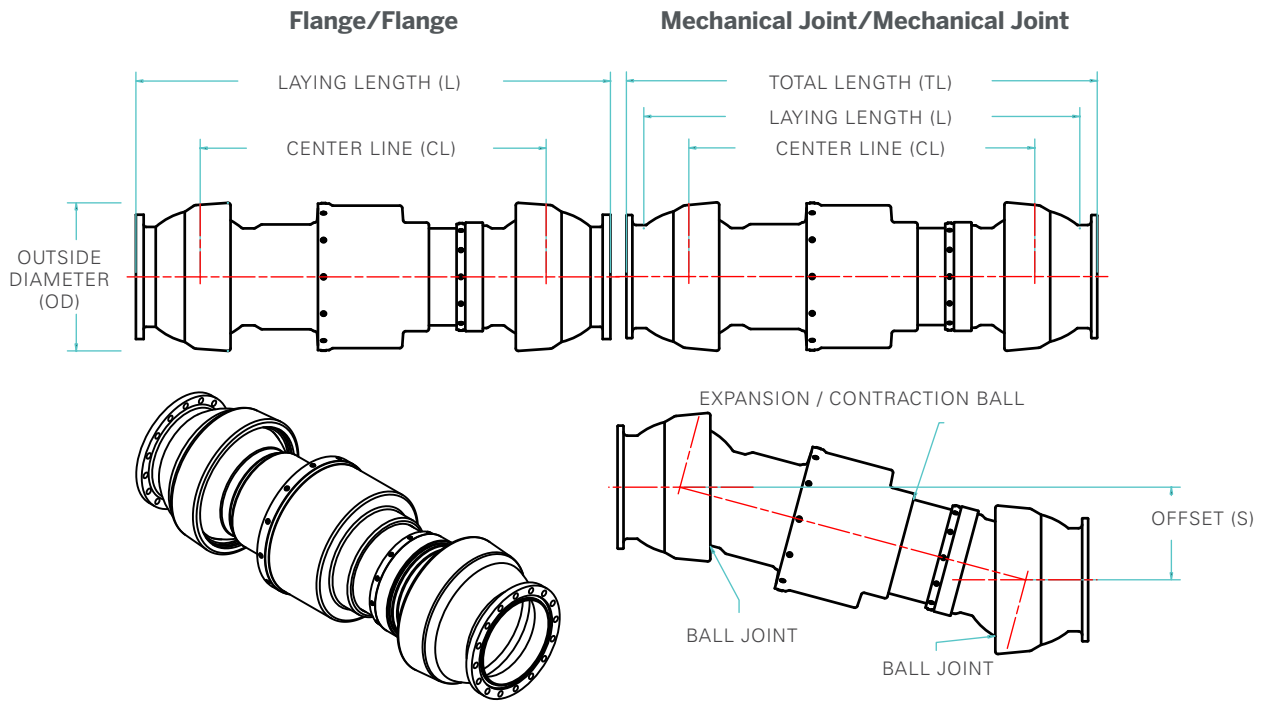

FIG. 2 Flex-Tend Force Balanced Submittal Drawing

TABLE 1 Flex-Tend Force Balanced Submittal Reference Drawing - Flange by Flange

Nominal Pipe Size (mm)	OD (mm)	Deflection Angle per ball (degrees)	Max. Expansion (mm)	CL (mm)	S (mm)	Series Number	L (mm)	Weight (kg)
50	157.48	25	165.10	1135.38	500.38	4402F20B	"1236.98 (-45.72,+119.38)"	-
80	259.08	20	203.20	1079.50	403.86	4403F20B	1300.48 (-76.2,+127)	-
100	259.08	20	203.20	1079.50	403.86	4404F20B	1366.52 (±101.6)	93.64
150	312.42	20	203.20	1117.60	419.10	4406F20B	1442.72 (±101.6)	143.64
200	378.46	20	203.20	1221.74	452.12	4408F20B	1597.66 (±101.6)	225.45
250	459.74	20	203.20	1285.24	474.98	4410F20B	1701.80 (±101.6)	288.64
300	528.32	20	203.20	1343.66	492.76	4412F20B	1828.80 (±101.6)	400
350	673.10	15	254.00	1658.62	444.50	4414F20B	2324.1 (±127)	803.64
400	673.10	15	254.00	1658.62	444.50	4416F20B	2250.44 (±127)	776.82
450	756.92	15	254.00	1765.30	472.44	4418F20B	2423.16 (±127)	1105.00
500	840.74	15	304.80	1905.00	510.54	4420F20B	2420.62 (±152.40)	1316.82
600	993.14	15	304.80	2075.18	523.24	4424F20B	2816.86 (±152.40)	1972.73

Note: Larger sizes available on request.



Scan for more
information

Disclaimer: While every effort has been made to ensure that the information in this document is correct and accurate, users of Hygrade Water product or information within this document must make their own assessment of suitability for their particular application. Product dimensions are nominal only, and should be verified if critical to a particular installation. No warranty is either expressed, implied, or statutory made by Hygrade Water unless expressly stated in any sale and purchase agreement entered into between Hygrade Water and the user.

November 2019

0800 494 723
hygradewater.co.nz

102 Neilson Street
Onehunga, Auckland 1061, New Zealand
PO Box 58142, Botany, Auckland 2163

