

# Flex-Tend® Flexible Expansion Joint

Flex-Tend expansion joints for protection of infrastructure pipe lines from motion, and shear and provide seismic resilience.



TECHNICAL GUIDE: **PF8.1**

## Applications

Tank settling and other differential settling

Bridge crossings and other underground to aerial transitions

Active fault crossings and liquefaction

## Product Attributes

Ball ends

Telescopic center sections

Low contribution to mechanical thrust

Large movement ranges

Above or below ground installation

## Approvals/Standards

All wetted parts coated with NSF61  
Approved FBE

100% test program for all completed units

Flanges available in ANSI, AS and EN standards

## Quality

NSF-61 Health and Safety Effects

AWWA C213 coating standards

Poly Sleeves to AWWA C116

The Flex-Tend flexible expansion joint is specifically designed to allow pipe movement. It protects pipelines from any shear caused by fault lines, structural settling and transition from one structure to another. With its ease of movement it contributes significantly less mechanical force to the pipe line.

### Design Specifications

- Ball ends allow up to 20 degrees of deflection
- Telescopic center sections can be added together for increased extension
- Low contribution to mechanical thrust
- Large movement ranges
- Above or below ground installation

### Applications

- Tank settling and other differential settling such as vessel to vessel
- Bridge crossings and other underground to areal transitions
- Active fault crossings and liquefaction
- Near roadways and dams
- Across any unstable ground

### Flex-Tend Double Ball Submittal Reference Drawing – Flange by Flange

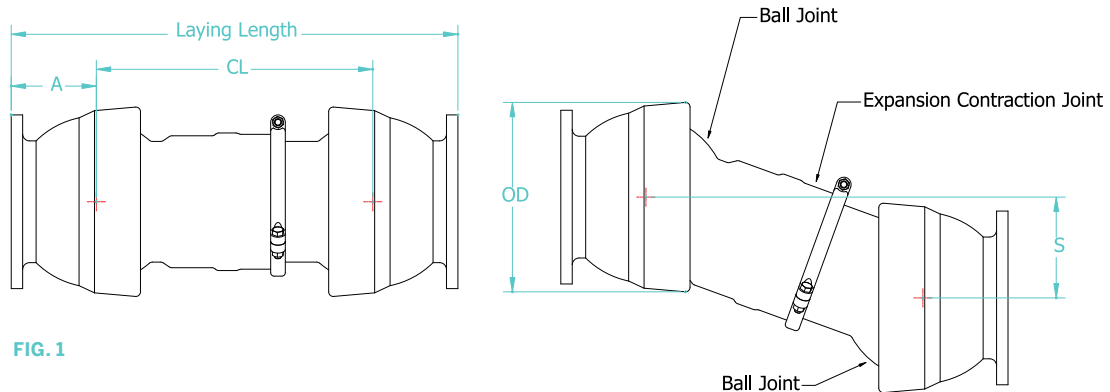

FIG. 1

### Flex-Tend Single Ball Submittal Reference Drawing – Flange by Flange

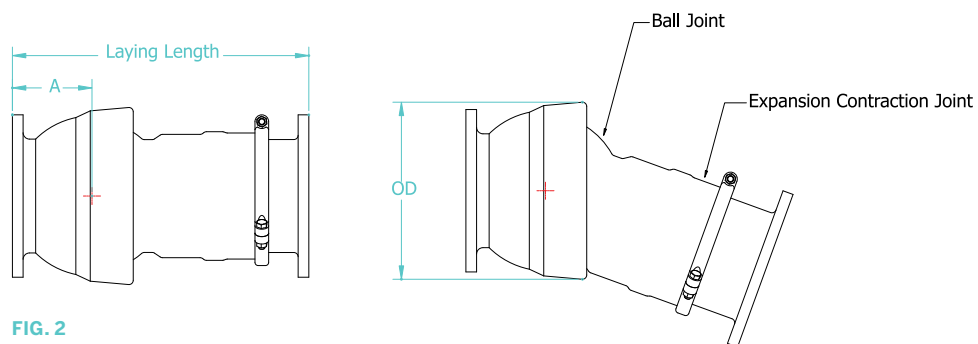

FIG. 2

**Note:**

f) Deflection in degrees per ball

††) The expansion values listed represent the total movement for the particular size and configuration. Unless otherwise specified, FLEX-TEND assemblies are preset at factory to reserve 50% of total movement for expansion and 50% for contraction.

"Laying, Total, and CL" lengths reflects the standard 50% / 50% preset condition. Modifying the preset ratio requires a corresponding modification of these lengths.

## Flex-Tend Double Ball Submittal Reference Drawing – Flange by Flange

TABLE 1

Nominal Pipe Size	OD	Deflection per ball† (degrees)	A	Expansion††	Laying Length	CL	S (offset)	Weight (kg)	Assembly Number
50	154.94	20	99.06	101.6 (+69.85, -31.75)	604.52	406.4	157.48	19.98	402F20
				101.60	901.70 (±50.8)	546.1 (±50.8)	190.50	86.71	403F20
80	233.68	20	177.8	203.20	1290.32 (±101.6)	934.72 (±101.6)	322.58	106.69	403F21
				304.80	1676.4 (±152.4)	1320.8 (±152.4)	454.66	127.12	403F22
100	275.59	20	142.748	101.60	864.62 (±50.8)	579.37 (±50.8)	215.65	73.09	404F20
				203.20	1251.97 (±101.6)	966.72 (±101.6)	365.51	95.34	404F21
150	311.912	20	156.718	304.80	1639.32 (±152.4)	1404.87 (±152.4)	515.37	118.95	404F22
				101.60	915.67 (±50.8)	601.98 (±50.8)	223.27	101.24	406F20
200	376.428	20	175.514	203.20	1278.38 (±101.6)	202.69 (±101.6)	364.74	129.39	406F21
				304.80	1641.09 (±152.4)	1327.4 (±152.4)	506.22	157.08	406F22
250	457.962	20	208.534	101.60	1026.41 (±50.8)	675.39 (±50.8)	248.41	154.36	408F20
				203.20	1458.21 (±101.6)	1109.73 (±101.6)	414.27	196.13	408F21
300	526.288	20	236.474	304.80	1895.09 (±152.4)	1544.07 (±152.4)	580.14	238.35	408F22
				101.60	1137.92 (±50.8)	720.85 (±50.8)	263.91	231.54	410F20
355	635	15	345.44	203.20	1539.24 (±101.6)	1122.17 (±101.6)	418.59	294.19	410F21
				304.80	1940.56 (±152.4)	1523.49 (±152.4)	573.28	356.39	410F22
400	635	15	345.44	101.60	1241.04 (±50.8)	768.1 (±50.8)	280.16	315.08	412F20
				203.20	1646.17 (±101.6)	1173.23 (±101.6)	436.12	381.81	412F21
450	774.7	15	353.06	304.80	2051.3 (±152.4)	1578.36 (±152.4)	592.07	449.01	412F22
				203.20	1638.3 (±101.6)	1117.6 (±101.6)	299.47	603.37	414F20
500	774.7	15	289.56	406.40	2308.86 (±203.2)	1790.7 (±203.2)	479.81	733.66	414F21
				609.60	2981.96 (±304.8)	2453.64 (±304.8)	659.38	864.42	414F22
600	947.42	15	393.7	203.20	1866.9 (±101.6)	1176.02 (±101.6)	315.21	547.07	416F20
				406.40	2578.1 (±203.2)	1884.68 (±203.2)	504.95	697.80	416F21
750	1120.14	15	424.18	609.60	3289.3 (±304.8)	2593.34 (±304.8)	694.94	848.53	416F22
				203.20	1849.12 (±101.6)	1193.8 (±101.6)	319.79	864.87	418F20
900	1285.24	15	431.8	406.40	2537.46 (±203.2)	1882.14 (±203.2)	504.44	1043.29	418F21
				609.60	3225.8 (±304.8)	2567.94 (±304.8)	688.09	1221.26	418F22
1060	1682.75	12	547.624	203.20	1752.6 (±101.6)	1165.86 (±101.6)	312.42	878.04	420F20
				406.40	2438.4 (±203.2)	1859.28 (±203.2)	498.09	1070.53	420F21
1200	1704.34	12	571.5	609.60	3136.9 (±304.8)	2550.16 (±304.8)	683.26	1263.03	420F22
				203.20	2108.2 (±101.6)	1325.88 (±101.6)	355.35	1470.51	424F20
1060	1682.75	12	547.624	406.40	2806.7 (±203.2)	2019.3 (±203.2)	541.02	1796.93	424F21
				609.60	3492.5 (±304.8)	2712.72 (±304.8)	726.95	2123.81	424F22
750	1120.14	15	424.18	254.00	2506.98 (±127)	1658.62 (±127)	444.50	2291.34	430F20
				508.00	3378.2 (±254)	2514.6 (±254)	673.86	2745.34	430F21
900	1285.24	15	431.8	762.00	4241.8 (±381)	3352.8 (±381)	898.40	3198.88	430F22
				254.00	523.8 (±127)	1600.2 (±127)	428.75	3231.57	436F20
1060	1682.75	12	547.624	508.00	3327.4 (±254)	2463.8 (±254)	660.15	3875.80	436F21
				762.00	4191 (±381)	3327.4 (±381)	891.54	4519.57	436F22
1200	1704.34	12	571.5	609.60	4033.52 (±304.8)	2890.52 (±304.8)	584.45	6434.09	442F20
1200	1704.34	12	571.5	609.60	4033.52 (±304.8)	2890.52 (±304.8)	739.90	7785.19	448F20

## Flex-Tend Single Ball Submittal Reference Drawing – Flange by Flange

TABLE 2

Nominal Pipe Size	OD	Deflection per ball† (degrees)	A	Expansion††	Laying Length	Weight (kg)	Assembly Number
80	233.68	20	177.8	101.6	591.82 (±50.8)	53.57	403F10
				203.2	1061.72 (±101.6)	74.00	403F11
				304.8	1531.62 (±152.4)	94.43	403F12
100	275.59	20	142.748	101.6	645.92 (±50.8)	50.85	404F10
				203.2	1033.27 (±101.6)	71.28	404F11
				304.8	1420.62 (±152.4)	91.71	404F12
150	311.912	20	156.718	101.6	695.71 (±50.8)	69.01	406F10
				203.2	1058.42 (±101.6)	96.70	406F11
				304.8	1421.13 (±152.4)	124.40	406F12
				101.6	761.49 (±50.8)	110.32	408F10

**TABLE 2**

Nominal Pipe Size	OD	Deflection per ball† (degrees)	A	Expansion††	Laying Length	Weight (kg)	Assembly Number
200	376.428	20	175.514	203.2	1195.83 (±101.6)	152.09	408F11
				304.8	1630.17 (±152.4)	194.31	408F12
250	457.962	20	208.534	101.6	832.87 (±50.8)	162.99	410F10
				203.2	1234.19 (±101.6)	225.18	410F11
				304.8	1635.51 (±152.4)	287.84	410F12
300	526.288	20	236.474	101.6	880.87 (±50.8)	212.47	412F10
				203.2	1286 (±101.6)	279.66	412F11
				304.8	1691.13 (±152.4)	346.40	412F12
355	635	15	345.44	203.2	1224.28 (±101.6)	399.52	414F10
				406.4	1889.76 (±204)	530.27	414F11
				609.6	2565.4 (±304.8)	660.12	414F12
400	635	15	345.44	203.2	1358.9 (±101.6)	413.59	416F10
				406.4	2070.1 (±204)	564.32	416F11
				609.6	2781.3 (±304.8)	715.05	416F12
450	774.7	15	353.06	203.2	1358.9 (±101.6)	558.87	418F10
				406.4	2039.2 (±204)	737.30	418F11
				609.6	2727.96 (±304.8)	915.26	418F12
500	774.7	15	289.56	203.2	1270 (±101.6)	579.76	420F10
				406.4	1955.8 (±204)	771.80	420F11
				609.6	2654.3 (±304.8)	958.39	420F12
600	947.42	15	393.7	203.2	1447.8 (±101.6)	945.68	424F10
				406.4	2146.3 (±204)	1264.84	424F11
				609.6	2844.8 (±304.8)	1591.72	424F12
750	1120.14	15	424.18	254	1704.35 (±127)	1658.92	430F10
				508	2578.1 (±254)	2086.13	430F11
				762	3449.32 (±381)	2612.77	430F12
900	1285.24	15	431.8	254	1826.26 (±127)	2141.97	436F10
				508	2705.1 (±254)	2785.74	436F11
				762	3581.4 (±381)	3429.52	436F12
1200	1704.34	12	571.5	609.6		5455.26	448F10



**FIG. 3**



**FIG. 4**



Scan for more information

**Disclaimer:** While every effort has been made to ensure that the information in this document is correct and accurate, users of Hygrade Water product or information within this document must make their own assessment of suitability for their particular application. Product dimensions are nominal only, and should be verified if critical to a particular installation. No warranty is either expressed, implied, or statutory made by Hygrade Water unless expressly stated in any sale and purchase agreement entered into between Hygrade Water and the user.

March 2019