

# ÖZKAN Foot Valve

For pump applications to reduce manual priming from pump drain back.



TECHNICAL GUIDE: **VH4.13**

## Applications

Vertical pipelines only

Raw water

River water

Grey water

Screened effluent

Pump Suction

## Product Attributes

Axial design with basket strainer

Metal seated or resilient seated

Short closing stroke

Low head loss

High corrosion resistance

## Approvals/Standards

EN 558-1 Series 13 and 14 face to face dimensions

AS4087 Flanges

Working tests to EN 1074 EN 12266

## Quality

ISO 9001:2008 Quality Management

# Özkan Foot Valve

## Design Specifications

Özkan Foot Valves are designed to prevent the pump suction line from draining after pump shutdown. This eliminates the need for priming.

They comprise of spring loaded discs and inlet strainers providing quick response to flow changes while straining the incoming water. Through this unique valve the water hammer effect is minimised and quick closing is achieved while preventing debris from entering the pipe.

Diameter	Pressure
DN100-1000	PN 10-16

## Design Features

TABLE 1 Design Features

Part No.	Description	Material
1	Body	Ductile iron EN-GJS-400-15
2	Disc	Ductile iron EN-GJS-400-15
3	Retaining ring	Steel S235JR
4	Sealing ring	EPDM
5	Hex.socket head cap screw	Stainless steel A2
6	Shaft	Stainless steel X20Cr13
7	Shaft support	Ductile cast iron EN-GJS-400-15
8	Bearing bush	Bronze
9	Hex.socket head cap screw	Stainless steel A2
10	O-ring	EPDM
11	Hex.socket set screw	Stainless steel A2
12	Hex.socket set screw	Stainless steel A2
13	Basket strainer	Steel-Galvanized

**Note:** Other material grades are available upon request.

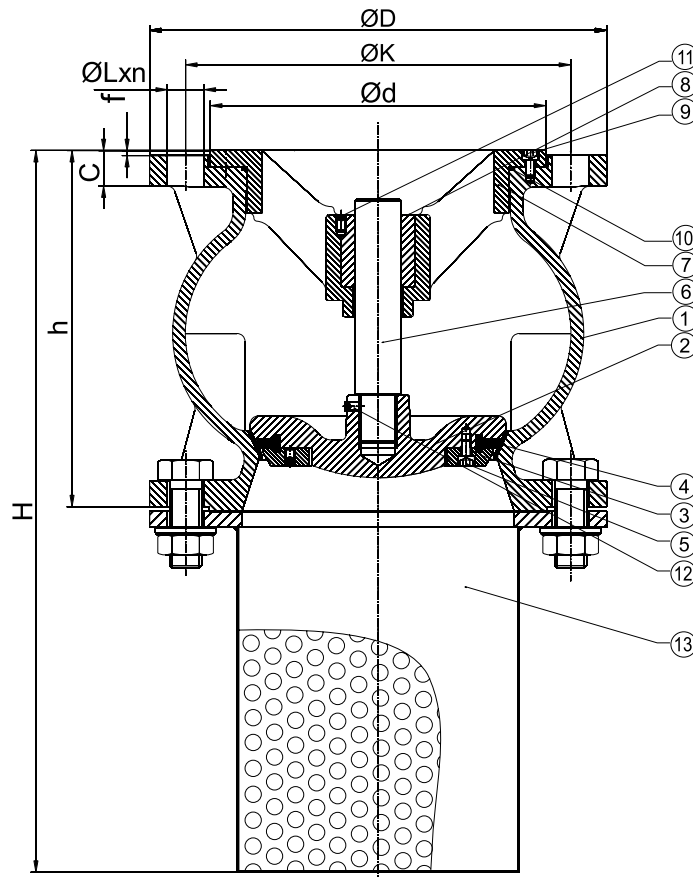

FIG. 1 DN 100 - DN 200

## Technical Specifications

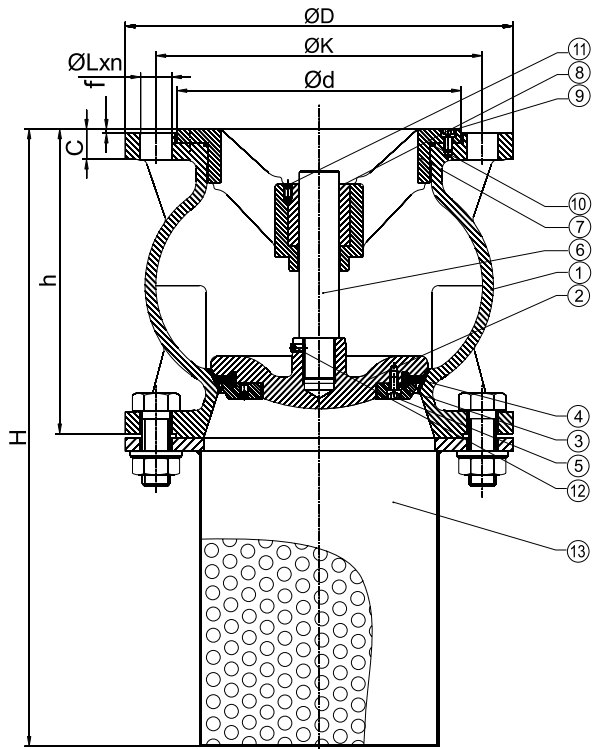

FIG. 2 DN 100 - DN 200

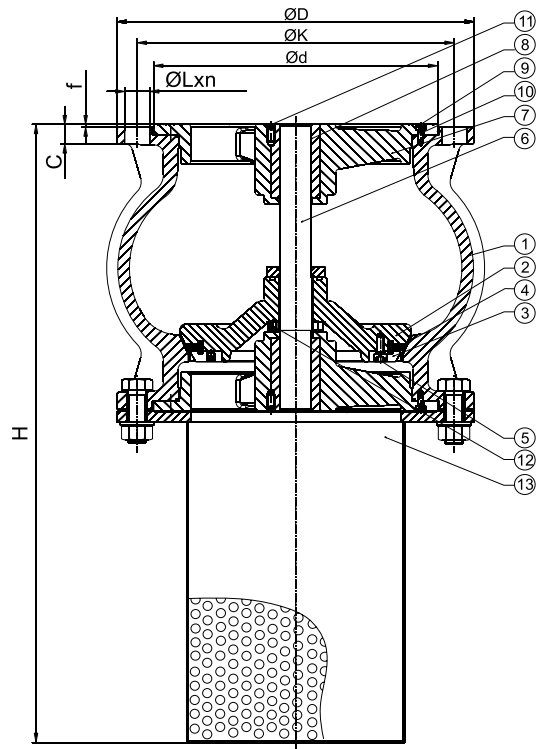

FIG. 3 DN 250 - DN 1000

TABLE 2 Foot Valve PN10 Technical Information

DN	H	h	ØD	Øk*	C	Weight (KG)
100	325	175	220	180	19.0	26
125	388	200	250	210	19.0	34
150	450	225	285	240	19.0	45
200	575	275	340	295	20.0	65
250	700	325	405	350	22.0	112
300	825	375	460	400	24.5	145
350	950	425	520	460	26.5	-
400	1075	475	580	515	28.5	216
500	1300	550	730	620	31.5	427
600	1500	600	845	725	36.0	560
700	1700	650	910	840	40.0	725
800	1900	700	1025	950	43.0	790
900	2000	800	1185	1050	50.0	-
1000	2100	900	1230	1160	40.0	1680

**Note:** Please contact us for other sizes and pressure rates.

\* EN1092 Flange pattern shown. Multiple flange standards available.

TABLE 3 Foot Valve PN16 Technical Information

DN	H	h	ØD	Øk	C	Weight (KG)
100	325	175	220	180	19.0	26
125	388	200	250	210	19.0	34
150	450	225	285	240	19.0	45
200	575	275	340	295	20.0	65
250	700	325	405	355	22.0	112
300	825	375	460	410	24.5	145
350	950	425	520	470	26.5	-
400	1075	475	580	525	28.0	216
500	1300	550	715	650	31.5	447
600	1500	600	840	770	36.0	580
700	1700	650	910	840	40.0	750
800	1900	700	1025	950	43.0	803
900	2000	800	1185	1050	50.0	-
1000	2100	900	1255	1170	50.0	1680

**Note:** Please contact us for other sizes and pressure rates.

\* EN1092 Flange pattern shown. Multiple flange standards available.



Scan for more  
information

**Disclaimer:** While every effort has been made to ensure that the information in this document is correct and accurate, users of Hygrade Water product or information within this document must make their own assessment of suitability for their particular application. Product dimensions are nominal only, and should be verified if critical to a particular installation. No warranty is either expressed, implied, or statutory made by Hygrade Water unless expressly stated in any sale and purchase agreement entered into between Hygrade Water and the user.

**January 2020**

**0800 494 723**  
**hygradewater.co.nz**

**102 Neilson Street**  
Onehunga, Auckland 1061, New Zealand  
PO Box 58142, Botany, Auckland 2163

