

Hawle E3 Resilient Seated Gate Valves DN50 – DN300

The Hawle E3 Gate Valves are a PN16 rated, resilient seated gate valve that is compliant with AS2638.2:2011. European designed and manufactured for a long life and reliable operation in water networks, they are also covered by the Hawle 10 Year “Quality Warranty” when in use on potable water applications.



TECHNICAL GUIDE: **VH1.10**

Applications

Potable water networks
Bulk water storage
Process water systems
Pump stations

Product Attributes

Hawle 10 Year Quality Warranty
Wear resistant wedge guides
Low closing torques at full differential pressure
Smooth straight through bore
Suitable for actuation

Approvals/Standards

AS2638.2:2011 Gate Valves for Water Works – Resilient Seated
Flanges to AS 4087 Figure B5
WSAA Product Appraisal Report 1904 Issue 2

Quality

ISO 9001 Quality Management Systems

Hawle E3 Resilient Seated Gate Valves DN50 – DN300

The Hawle E3 resilient seated gate valve has been developed from their long serving and successful E2 gate valve, with some small changes made to further enhance the longevity and reliability of the E3 Valve. The wear resistant wedge guides ensure easy reliable operation, and low torque opening and closing.

Product Features

- Complies with AS/NZS 2638.2:2011 (DN80 - DN300)
- 100% suitable for underground installation.
- Anti-Clockwise closing as standard. Clockwise Closing also available.
- Smooth straight-through bore allows for easy cleaning with a pig.
- Duplex stainless-steel spindle with cold rolled thread.
- The ductile iron wedge is connected to the wedge nut with a flexible link and embedded in a vulcanised elastomer. This snug fit dampens vibration during opening and closing of the valve.
- Extended edge protection to avoid body damage during transport, storage and assembly.
- Spindle is supported by POM friction washers or axial ball bearing for minimum closing forces.
- Valves to DN 250 - 300 include ball bearing and additional sliding discs
- Can be easily opened or closed without a by-pass valve or power assistance, even at a differential of 16 bar.

- Spindle O-rings are replaceable under operating pressure (according to ISO 7259).
- Designed for easy fitment of actuators and other accessories.
- The epoxy coating system complies with the requirements of the relevant German and Australian Standards for contact with Potable Water.
- Hawle 10 Year “Quality Warranty” when in use on potable water applications

Standard Version

- Supplied with Spindle Cap

Optional Accessories

- Handwheel
- Electric Actuator
- Position Indicator
- Extension Spindles
 - *Rigid*
 - *Telescopic*

TABLE 1

No.	Component	Materials/Description
1,2	Body & Bonnet	Body (1), bonnet (2), centering flange (16) made of ductile iron.
16	Coating	Epoxy powder coated inside and out
3	Wedge	Wedge made of ductile iron (DN 50 made of dezincification-resistant brass) with vulcanised elastomer all-over
4	Wedge Guide	Wedge guide made of wear-resistant plastic
5	Wedge Nut	Wedge nut made of dezincification-resistant brass
6	Spindle	Duplex stainless steel spindle with rolled thread and flat-rolled anti-friction surface
7	O-Ring Carrier	O-ring carrier made of brass, DN 50 – DN 200 with double bayonet
8	O-Rings	O-rings made of elastomer
9	Wiper Ring	Wiper ring made of PE (DN50 - 200)
10	Bonnet Gasket	Bonnet gasket made of elastomer
11	Allen Screws	Stainless steel allen screws, encased with an interlacing gasket and sealing compounds, for full corrosion protection
12	Edge Protection Ring	Extended edge protection made of PE to avoid damage
13	Spindle Bearing	Spindle bearing made of dezincification resistant brass
14	Friction Washers	Sliding discs made of POM
15	Safety Screw	Safety screw made of stainless steel
17	Centering Flange Gasket	Centering flange gasket made of elastomer (DN250 & DN300)
18	Spindle Bearing	Axial ball bearing permanently lubricated (DN250 & DN300)
19	Centering Ring	Centering ring made of POM (DN250 & DN300)
20	Spindle seals	Lip seals made of elastomer (DN250 & DN300)
21	Wiper Ring	Wiper ring made of elastomer (DN250 & DN300)

DN50 - DN200 Spindle bearing with sliding discs

DN250 - DN300 Spindle bearing with ball bearing and additional sliding discs

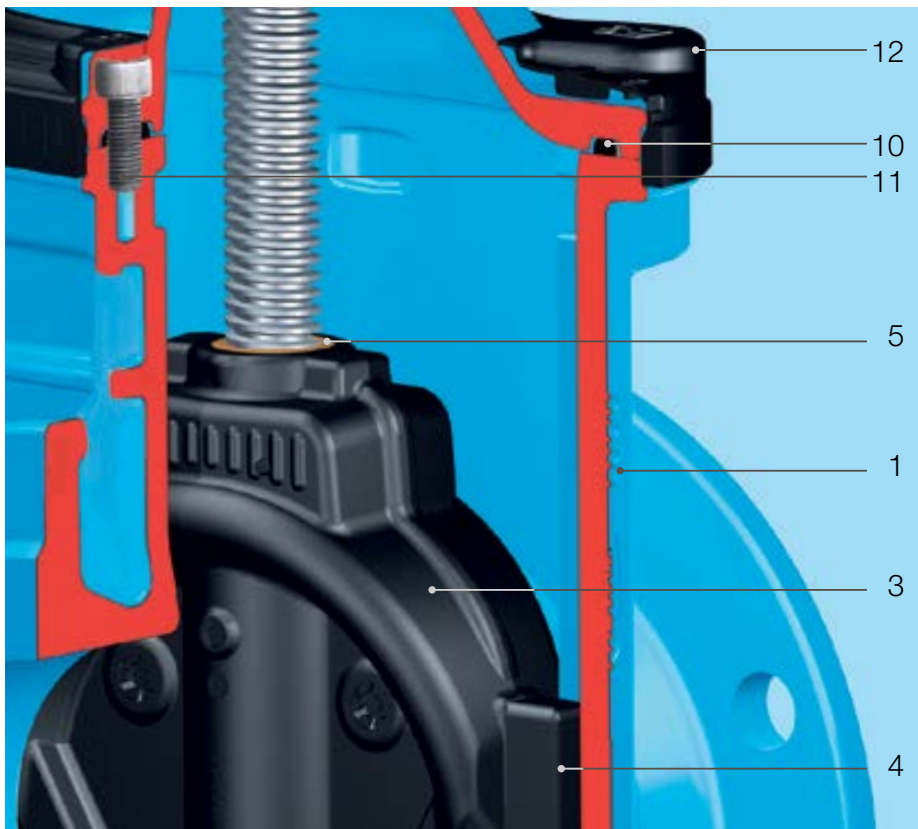
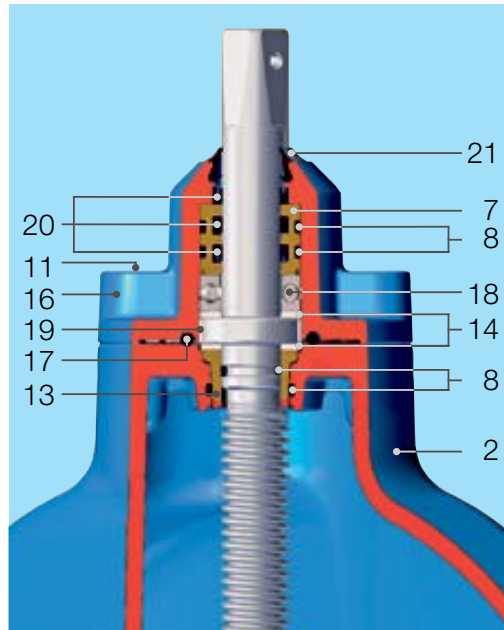
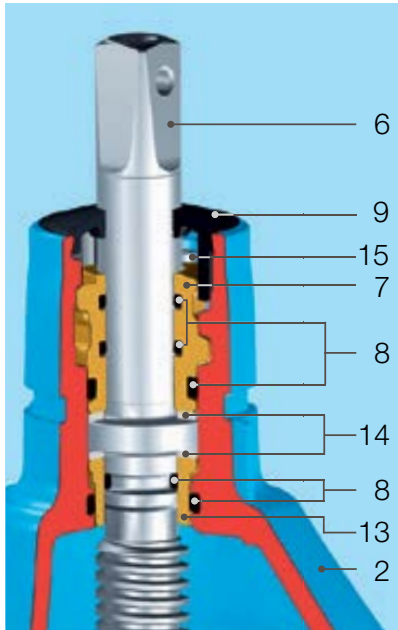

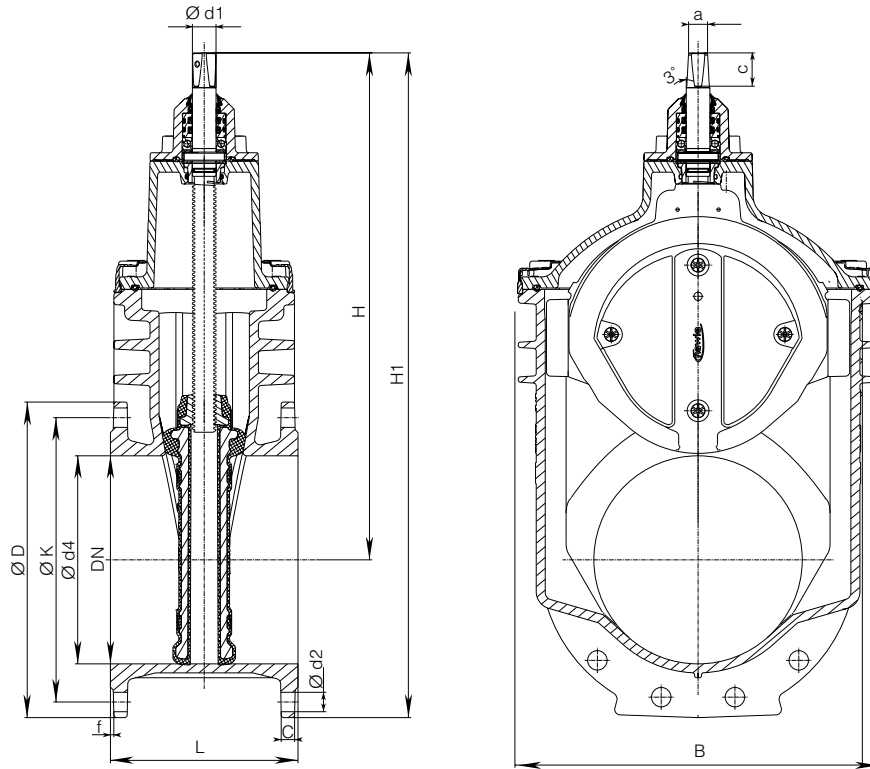

TABLE 2

Item Code	DN (mm)	PN (bar)	Flange (mm)			Bolts (mm)			Spindle (mm)			Valve (mm)				Weight (kg)	
			øD	C	øK	Qty.	Size	ød2	a	c	°w	ød1	H	H1	L**		B
VSDF-050-3	50	16	165	19	114	4	M16	19	14.8	30	3°	20.5	234	316.5	178	143	11
VSDF-080-3	80	16	200	19	146	4	M16	19	17.3	35	3°	24	312.5	412.5	203	180	19
VSDF-100-3	100	16	220	19	178	4	M16	19	19.3	38	3°	24	343	453	229	212	26
VSDF-150-3	150	16	285	19	235	8	M16	19	19.3	38	3°	26	433	576	267	289	45
VSDF-200-3	200	16	340	20	292	8	M16	19	24.3	48	3°	30	541	711	292	356	67.5
VSDF-250-3	250	16	400	22	356	8	M20	23	27.3	48	3°	34	649	849	330	432	104
VSDF-300-3	300	16	455	24.5	406	12	M20	23	27.3	48	3°	34	731	959	356	518	153.5

Notes:

For sizes DN350-DN600 refer to **VH1.2B Hawle E2 Flanged Sluice Valve DN350-600 Technical Guide**.

* Above flanged to AS 4087 Fig B5. Other flange patterns such as Table E and EN1092 PN16 available on request.

**Other body lengths available on special order.

*** Sizes DN100 -DN300 also available in clockwise closing

TABLE 3 Maximum required operating torque at 16 bar

Valve Size	Closing Torque	Adjusted Operating Torque	Turns to Close
DN 50	30 Nm	35	10
DN 80	35 Nm	40	16
DN 100	40 Nm	45	20
DN 150	50 Nm	55	30
DN 200	70 Nm	80	34
DN 250	90 Nm	100	42
DN 300	120 Nm	140	50



Scan for more information

Disclaimer: While every effort has been made to ensure that the information in this document is correct and accurate, users of Hygrade Water product or information within this document must make their own assessment of suitability for their particular application. Product dimensions are nominal only, and should be verified if critical to a particular installation. No warranty is either expressed, implied, or statutory made by Hygrade Water unless expressly stated in any sale and purchase agreement entered into between Hygrade Water and the user.

March 2025