

# Calder K Strap Alignment Clamp

The K Pattern Clamp is a lightweight, fast set up clamp that will hold HDPE pipe securely in position during the weld process for pipe sizes up to 500mm.

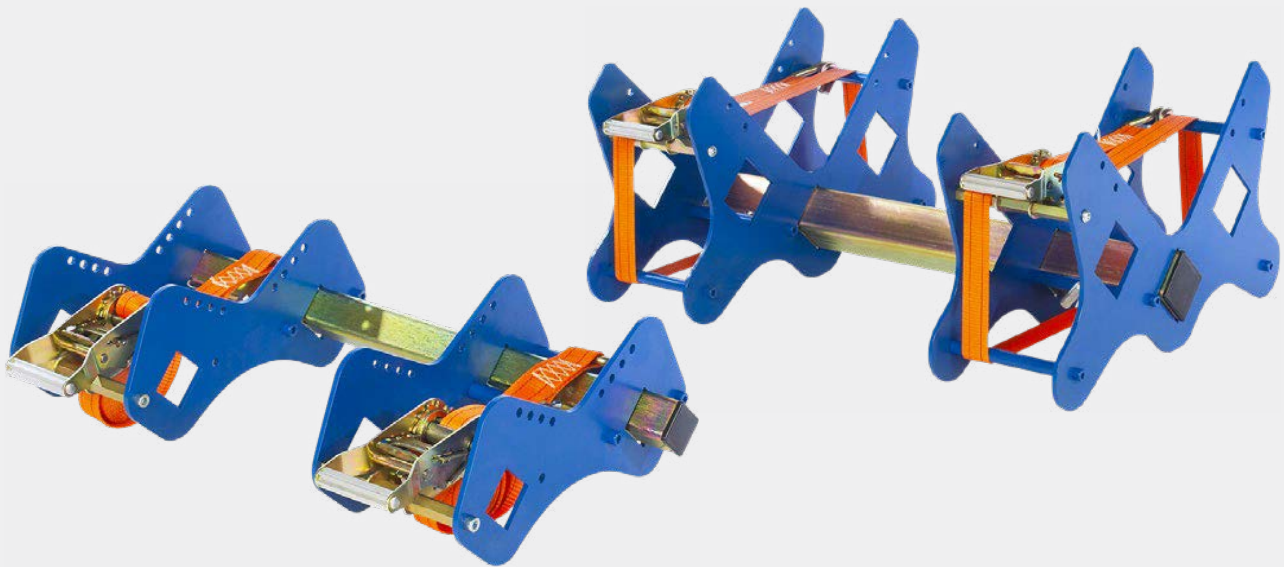

TECHNICAL GUIDE: **TA1.7**

## Applications

Electrofusion

Buttfusion

## Product Attributes

Suitable for 63mm-500mm PE pipe

Available with straight or angle  
maker base

Fast acting "tug and tension" straps

## Quality

ISO9001:2015

ISO14001:2015

The K Pattern Clamp is robust and compact, featuring a simple strap design and optional reducing plates to align pipe horizontally when using reducing fittings.

**Features**

- Quick to install and easy to use
- Pipe range 63mm-500mm
- Compact design
- Fast acting “tug and tensions” straps
- Available with straight or angle maker base
- No liners required



**TABLE 1** K Strap Clamp 2 Way with a Straight Base

Code	Description	Dimensions	Weight
CLAMPK063250	Alignment Clamp K Strap 63 - 250mm 2 Way Straight	910 x 340 x 270mm	10.8kg
CLAMPK125500	Alignment Clamp K Strap 125 - 500mm 2 Way Straight	940 x 370 x 230mm	22.4kg

**TABLE 2** K Strap Clamp 2 Way with an Angle Base

Code	Description	Dimensions	Weight
CLAMPK063250A	Alignment Clamp K Strap 63 - 250mm 2 Way Angle	940 x 370 x 230mm	13.2kg
CLAMPK125500A	Alignment Clamp K Strap 125 - 500mm 2 Way Angle	940 x 370 x 280mm	30.5kg

## Operating Instructions

### Instructions for Angle Maker Base

If an angled fitting is required an angle maker base should be used.

The angle maker base should be set up by:

1. First unscrewing the base screw with the provided Allen key.
2. Mate the ends of the bases at the appropriate angle and replace the countersunk screw and tighten it until the base pieces do not move separately. Do not overtighten as this may cause damage.

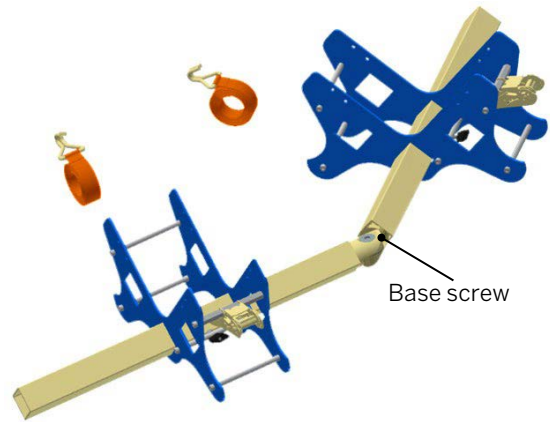

### Instructions for Clamps:

1. Insert the desired base (*straight or angle maker*) into the central square hole of the clamp.
2. Ensure the base locking wing nut (*A*) is securely tightened to stop the clamp moving independently of the base.
3. Pipe is to be placed in the V atop the clamp body (*B*).
4. Once pipe is positioned and ready to be constrained the straps can now be attached by firstly placing the straps' steel hook (*D*) around the cross bar (*C*) that is located on the opposite side to the ratchet mechanism.
5. The strap should then be passed over the pipe to the ratchet mechanism and threaded through the slot in the central rotating part of the ratchet mechanism as much as possible.
6. Ensuring the strap does not slip back through the slot begin to operate the ratchet mechanism as indicated below until it tightens the strap sufficiently around the pipe.

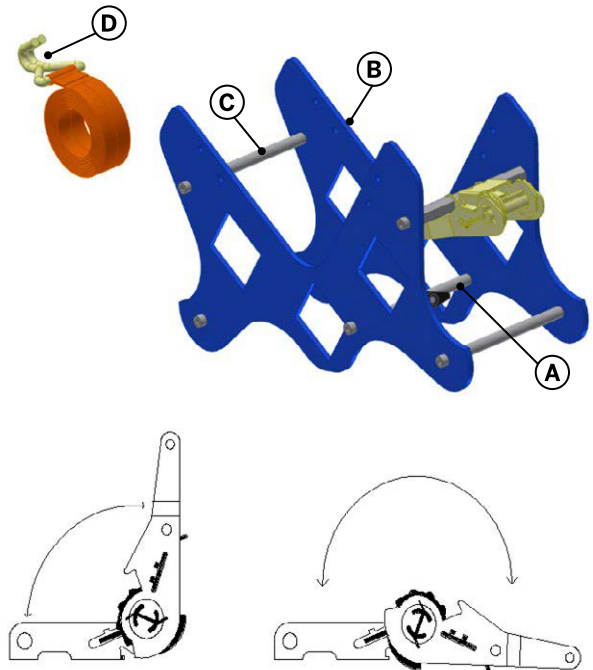

**Removal:**

1. To release the strap pressure, operate the ratchet mechanism release handle and fully open the ratchet mechanism as shown above.
2. Remove the strap from the ratchet mechanism and the hook end can be removed from the clamp at this stage
3. Release the base locking wing nut (A) by turning anticlockwise.
4. Slide clamp away from the base.

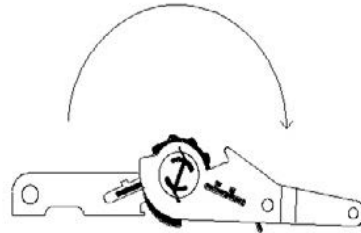
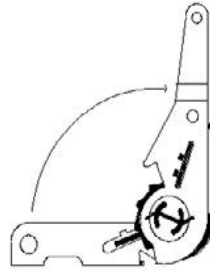
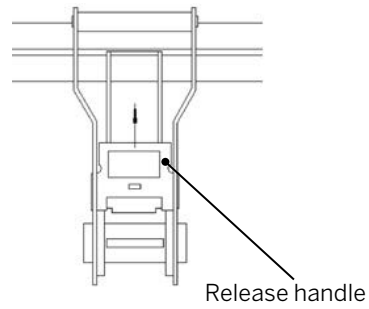

Scan for more  
information

**Disclaimer:** While every effort has been made to ensure that the information in this document is correct and accurate, users of Hygrade Water product or information within this document must make their own assessment of suitability for their particular application. Product dimensions are nominal only, and should be verified if critical to a particular installation. No warranty is either expressed, implied, or statutory made by Hygrade Water unless expressly stated in any sale and purchase agreement entered into between Hygrade Water and the user.

June 2024

0800 494 723  
hygradewater.co.nz

102 Neilson Street  
Onehunga, Auckland 1061, New Zealand  
PO Box 58 142, Botany, Auckland 2163

**HW** HYGRADE  
WATER